

5-10-15-20mA Temperature Compensated
Unipolar Current Regulator

- Limits and regulates current to 20mA.
- Rejects 50Hz / 60Hz ripple.
- Fast 2µSec settling time.
- <15% Overshoot.
- No external components.
- 250V Maximum Operating Voltage.
- Can be paralleled for higher current.

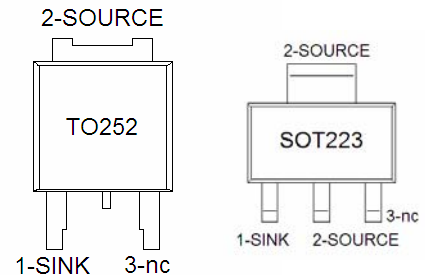

Description:

The CL1A is SimpleChips' 5-10-15-20 mA temperature-compensated unipolar current regulator. It is designed to be used with voltages from 6V to 250V DC and the temperature coefficient is optimized from -40C to 125C. SimpleChips' 5-10-15-20mA unipolar current regulator can source or sink constant current. For high voltage applications a heat sink can be connected to the Ground pin (Source) (pin 2), or the device can be mounted on a larger copper plate used as a heat sink. These devices can be paralleled for larger current drives or connected back-to-back for AC current limiting function.

These current regulators can be used for applications with AC or DC such as:

- serial LED drivers for industrial lamp indicators, signage, accent lighting, and automotive lighting.
- Power limiter in transformer input stage (mounted back to back).
- constant current source or sink.
- current reference or level translator.
- laser diode driver for VCSELs used in Optical Networking.

Functional Block Diagram:

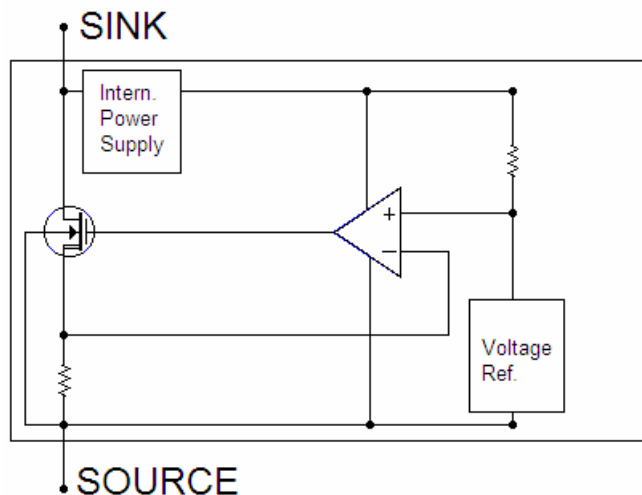



5-10-15-20mA Temperature Compensated Unipolar Current Regulator

Terminal Functions:

Terminal Name	SC_CL1A pin no.	Type	Description
Sink	1	HV Input	Sinks load current
Source	2	VH input	Usually Grounded. All voltages referenced to source. Sources load current

Absolute Maximum Ratings:

- Maximum Operating Voltage (see Note 1) 250 Volts DC
- Operating free air temperature range -40 degree C to 85 degree C
- Storage temperature -40 degree C to 85 degree C
- ESD tolerance, human body model 500 Volts

Stresses beyond those listed under "absolute maximum ratings" may cause permanent damage to the device. These are stress ratings only, and functional operation of the device at these or any other conditions beyond those indicated under "Recommended Operating Conditions" is not implied. Exposure to absolute-maximum-rated conditions for extended period may affect device reliability.

NOTE 1: All voltages are with respect to Source for 10Sec.

Recommended Operating Conditions:

	Min.	Max.	Unit
Operating Voltage (V Sink – V Source)	6	200	Volt DC
Operating free air temperature	-40	85	degree C
Operating chip temperature	-40	135	degree C

Thermal Characteristics (see note 2)

Temp. = 25 degree C unless otherwise specified

Parameter	Unit	Min.	Typ.	Max.
SOT223 thermal resistance minimum copper layout	C/Watt		160	
SOT223 thermal resistance (0.600inch X 0.500inch)	C/Watt		88	
SOT223 thermal resistance (1.000inch X 1.000inch)	C/Watt		67	
TO252 thermal resistance minimum copper layout	C/Watt		110	
TO252 thermal resistance (0.600inch X 0.500inch)	C/Watt		75	
TO252 thermal resistance (1.000inch X 1.000inch)	C/Watt		50	

Note 2: See page 8 for copper layout

5-10-15-20mA Temperature Compensated
Unipolar Current Regulator

Operating Characteristics

V Sink – V Source = 20V, Temp. = 25 degree C unless otherwise specified

20mA nominal

Parameter	Unit	Min.	Typ.	Max.
Regulated Current (I_{Lim})	mA	18.5	21.2	24.0
Regulated Current (I_{Lim}) at -40C	mA		20.4	
Regulated Current (I_{Lim}) at +85C	mA		20.8	
Absolute Temperature Coefficient (see note 1)	$\mu A / C$		24	
Minimum Operating voltage (Limits current to 90% of I_{Lim})	V	3.5	4.7	6.0
Voltage Coefficient 10V to 200V (pulse 10mSec)	mA/100V	n/a	1.0	2.0
Stabilisation time to 10% of final value	μSec		2.0	
Transient response to 10% to 90%	nSec		300	

15mA nominal

Parameter	Unit	Min.	Typ.	Max.
Regulated Current (I_{Lim})	mA	13.9	15.9	18.0
Regulated Current (I_{Lim}) at -40C	mA		15.3	
Regulated Current (I_{Lim}) at +85C	mA		15.6	
Absolute Temperature Coefficient (see note 1)	$\mu A / C$		18	
Minimum Operating voltage (Limits current to 90% of I_{Lim})	V	3.0	4.2	5.5
Voltage Coefficient 10V to 200V (pulse 10mSec)	mA/100V	n/a	.8	1.5
Stabilisation time to 10% of final value	μSec		2.0	
Transient response to 10% to 90%	nSec		300	

10mA nominal

Parameter	Unit	Min.	Typ.	Max.
Regulated Current (I_{Lim})	mA	9.3	10.6	12
Regulated Current (I_{Lim}) at -40C	mA		10.2	
Regulated Current (I_{Lim}) at +85C	mA		10.4	
Absolute Temperature Coefficient (see note 1)	$\mu A / C$		12	
Minimum Operating voltage (Limits current to 90% of I_{Lim})	V	2.5	3.7	5.0
Voltage Coefficient 10V to 200V (pulse 10mSec)	mA/100V	n/a	0.5	1.0
Stabilisation time to 10% of final value	μSec		2.0	
Transient response to 10% to 90%	nSec		300	

5.0mA nominal

Parameter	Unit	Min.	Typ.	Max.
Regulated Current (I_{Lim})	mA	4.6	5.3	6.0
Regulated Current (I_{Lim}) at -40C	mA		5.1	
Regulated Current (I_{Lim}) at +85C	mA		5.2	
Absolute Temperature Coefficient (see note 1)	$\mu A / C$		6.0	
Minimum Operating voltage (Limits current to 90% of I_{Lim})	V	2.0	3.2	4.5
Voltage Coefficient 10V to 200V (pulse 10mSec)	mA/100V	n/a	0.25	0.5
Stabilisation time to 10% of final value	μSec		2.0	
Transient response to 10% to 90%	nSec		300	

Note 1: see next pages for more details

5-10-15-20mA Temperature Compensated
Unipolar Current Regulator

Data shown for 20mA version.

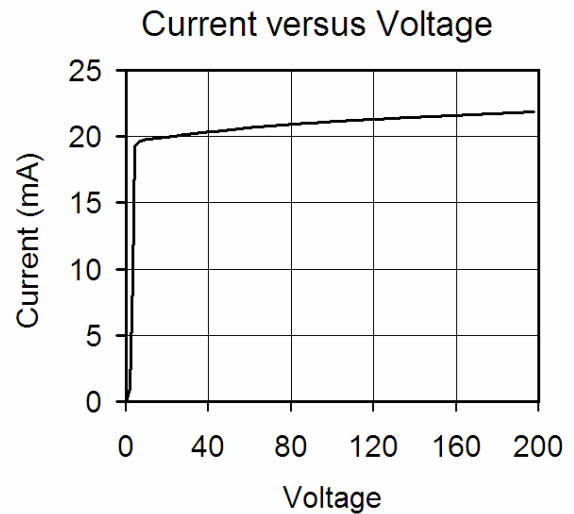
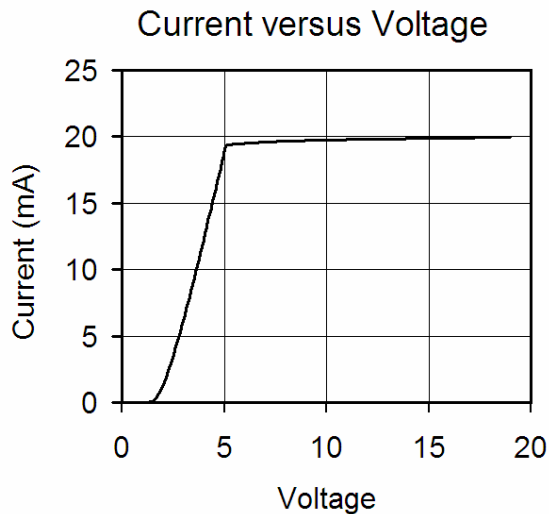

Maximum Voltage vs ambient temperature
SOT223 - 10% duty cycle

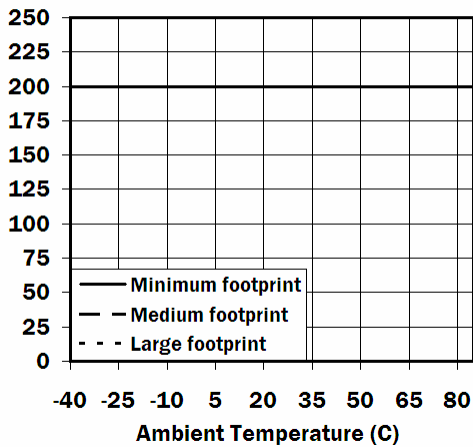

Maximum Voltage vs ambient temperature
SOT223 - 50% duty cycle

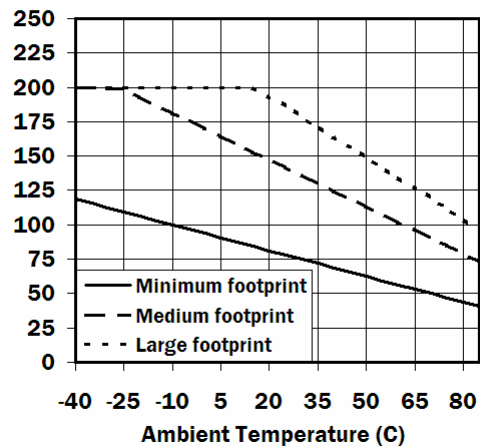

5-10-15-20mA Temperature Compensated
Unipolar Current Regulator

Maximum Voltage vs ambient temperature
SOT223 - 100% duty cycle

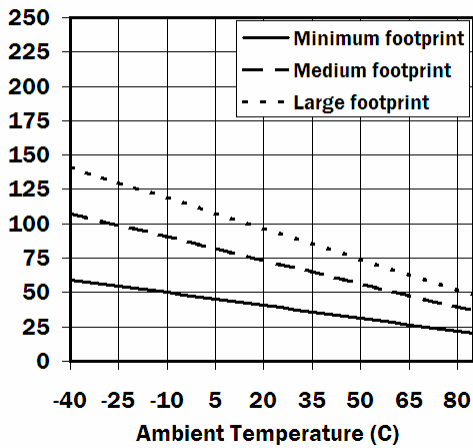

Maximum Voltage vs ambient temperature
T0252 - 50% duty cycle

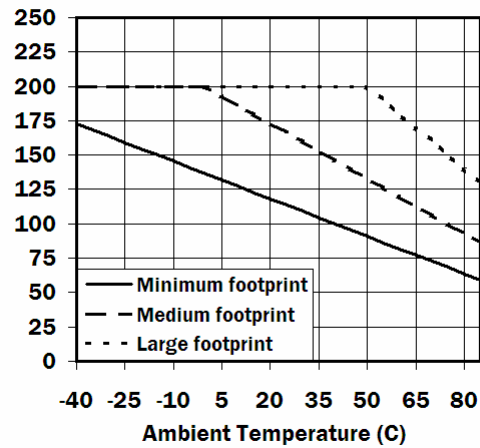

Maximum Voltage vs ambient temperature
T0252 - 100% duty cycle

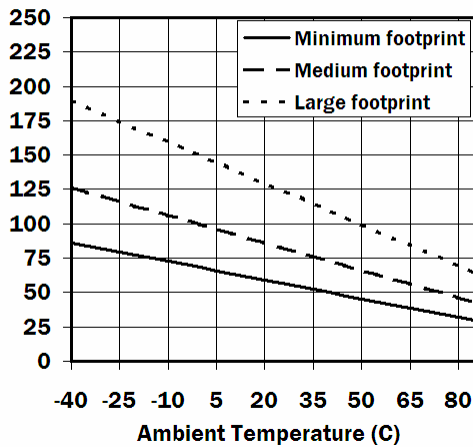

Relative Current Output
I(25C)=1.0

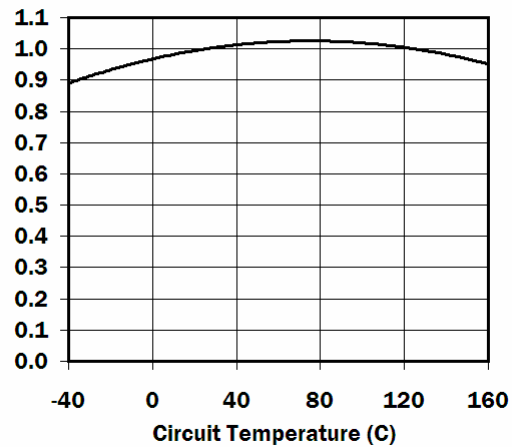

5-10-15-20mA Temperature Compensated
Unipolar Current Regulator

Transient Response
Turn-off Characteristics

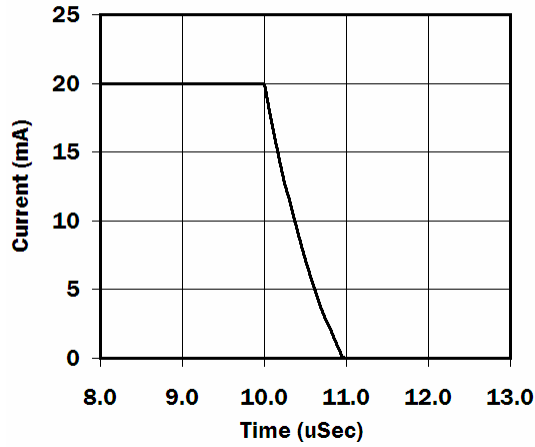

Transient Response
Turn-on Characteristics

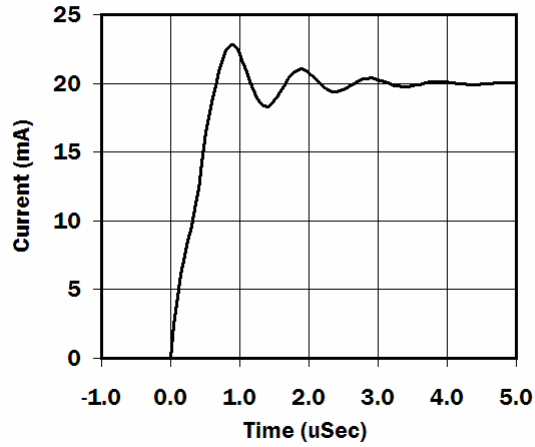

Transient Response
10uSec Pulse Characteristics

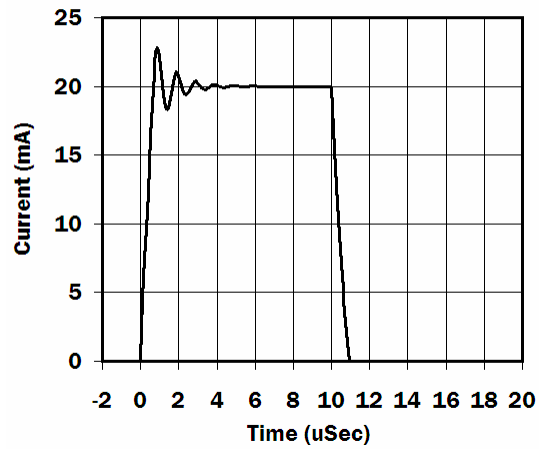

5-10-15-20mA Temperature Compensated Unipolar Current Regulator

Typical applications Sink and Source:

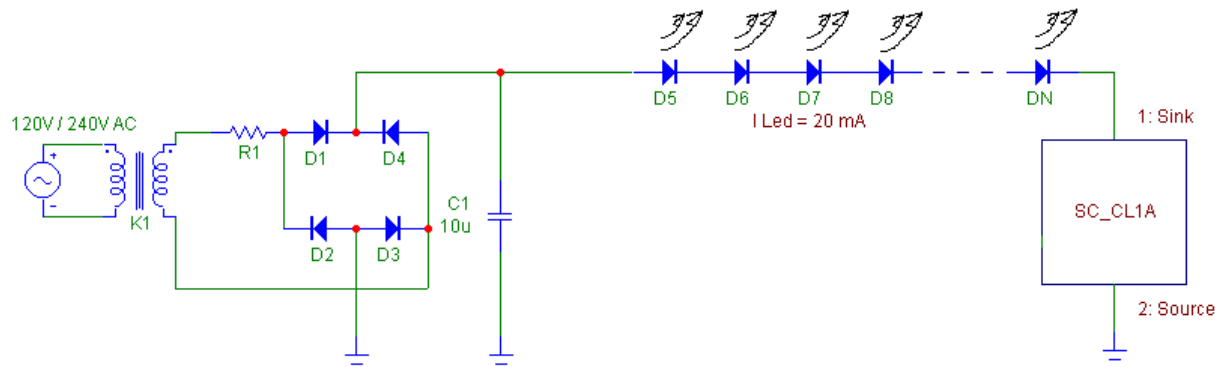

Packaging availability:

- SOT223
- TO252 (DPAK)
- Bare Die

Thermal properties test boards (Drawing to scale):

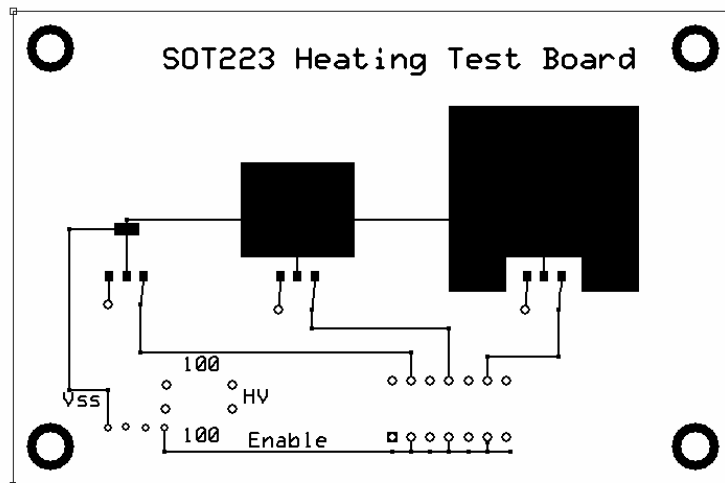
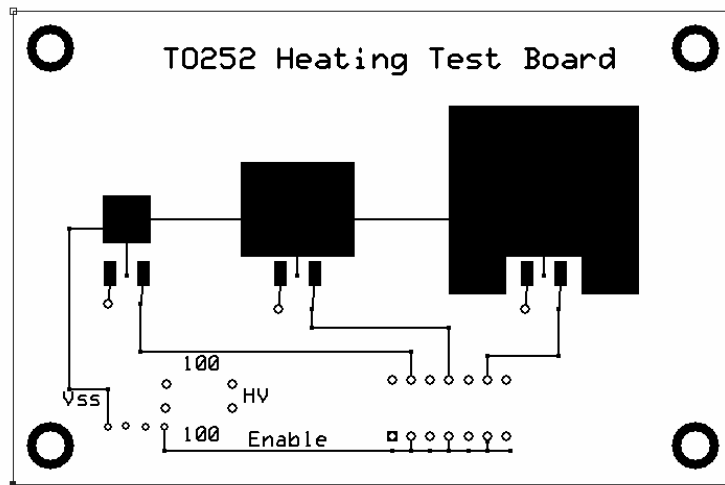

5-10-15-20mA Temperature Compensated
Unipolar Current Regulator

Package Description:

SOT223

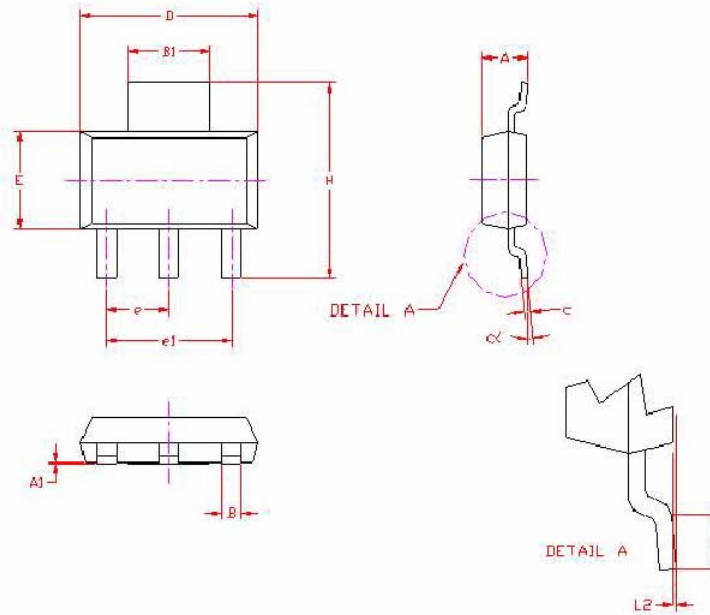

SYMBOL	MILIMETER		INCHES	
	MINIMUM	MAXIMUM	MINIMUM	MAXIMUM
A	1.55	1.80	.061	.071
A1	0.02	0.10	.0008	.004
B	0.60	0.80	.024	.031
B1	2.90	3.10	.114	.122
c	0.24	0.32	.009	.013
D	6.30	6.70	.248	.264
E	3.30	3.70	.130	.146
e	2.30 BSC		.090 BSC	
e1	4.60 BSC		.181 BSC	
H	6.70	7.30	.264	.287
L	0.91 MIN		.036 MIN	
L2	0.06 BSC		.0024 BSC	
α	0°	10°	0°	10°

Package Description:

TO252 (DPAK-3L)

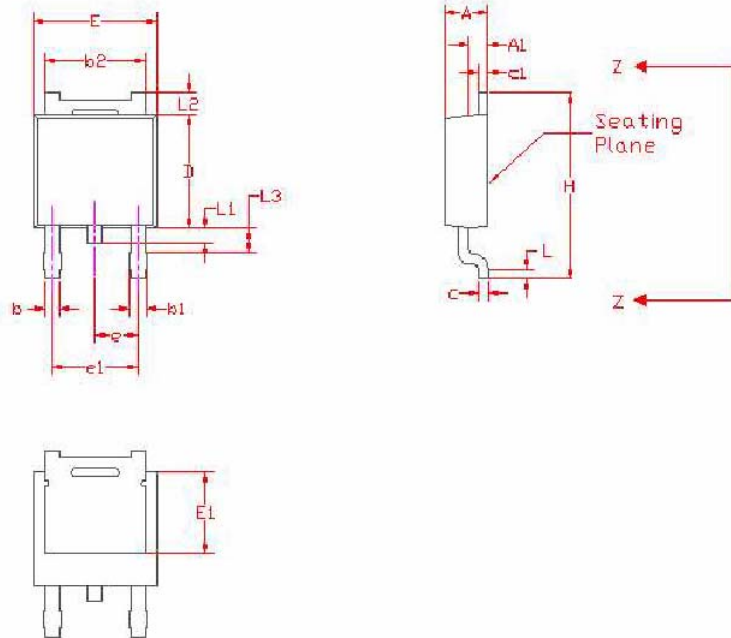

SYMBOL	MILIMETER		INCHES	
	MINIMUM	MAXIMUM	MINIMUM	MAXIMUM
A	2.19	2.38	.086	.094
A1	0.89	1.14	.035	.045
b	0.64	0.88	.025	.035
b1	0.76	1.14	.030	.045
b2	5.21	5.46	.205	.215
c	0.46	0.58	.018	.023
e1	0.46	0.58	.018	.023
D	5.97	6.22	.235	.244
E	6.35	6.73	.250	.265
E1	MIN 4.32		MIN .170	
e	2.28 (BSC)		.090 (BSC)	
e1	4.57 (BSC)		.180 (BSC)	
H	9.40	10.42	.370	.410
L	0.51	-	.020	-
L1	0.64	1.02	.025	.040
L2	0.88	1.27	.035	.050
L3	1.15	1.52	.045	.060